

# **TOW AND MOW**

# Twin 1000 &

# Twin 1270

## **OWNER'S GUIDE**

## **&**

## **USER MANUAL**

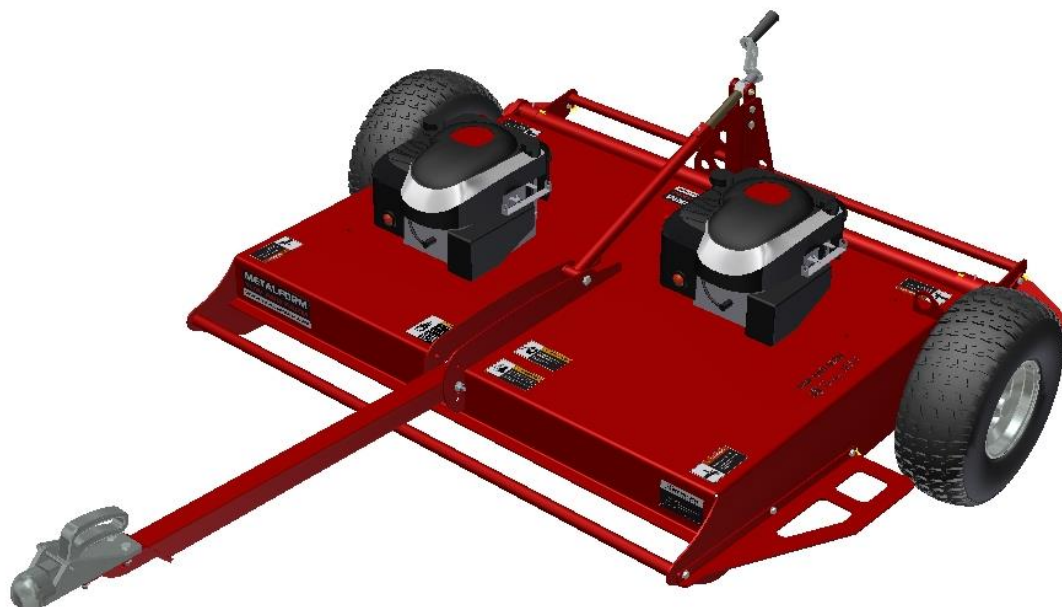

## DISCLAIMER!

Read this Manual from start to finish before attempting to assemble, use or maintain the Equipment to which it refers. Do not attempt assembly, use or maintenance unless you know what you are doing. We accept no responsibility if you fail to follow the instructions in this Manual.

If you do not understand a point in this Manual, don't guess. Don't take short cuts. If in doubt, stop! Contact us or our authorised representatives for advice. We are here to help.

The Equipment is designed for easy assembly and use by persons who are reasonably familiar with farm implements and machinery. However, some of the maintenance procedures may require special tools or consumables or a level of experience with farm implements and machinery than you may not possess. If you encounter any difficulties, contact us or your own mechanic or technician for assistance.

To reduce packaging and freight costs, the drawbar is not attached to the Equipment. Assembly of the drawbar to the Equipment is your responsibility.

For each customer, operating conditions will vary, sometimes greatly. Such variations may affect the Equipment's performance. We have no control over your unique operating environment. Hence, we make no representations or warranties concerning the Equipment's performance under your actual operating conditions.

We made every effort to explain the assembly, operating, maintenance and safety procedures as clearly and completely as possible. Nonetheless, it is not possible to anticipate, nor address, every conceivable problem that may arise. This problem is compounded by the fact that no two operating environments are exactly the same. Therefore, we are not able to guarantee that this Manual will address every issue or problem that might arise concerning the assembly, operation, maintenance or safety of the Equipment to which it relates.

This Manual is intended to provide you with general guidance. For specific guidance and support, contact us or our authorised representative.

If you do not follow the assembly, use, maintenance and safety procedures in this Manual, the Equipment may not function as expected. More seriously, it may cause property damage, personal injury or other losses.

Use the Equipment at your own risk. We accept no liability for direct, indirect, incidental, special, or consequential damages resulting from your failure to follow the assembly, use, maintenance and safety procedures in this Manual. The foregoing limitation extends to damages for personal injury, damages to your vehicle and other property damage, whether suffered by you or by a third party.

We used all due care in preparing this Manual. However, we accept no liability for errors or omissions.

We reserve the right to change the design or specifications of the Equipment, or the information in this Manual, without notice.

Assembly, use and maintenance of the Equipment is entirely your risk and responsibility.

## INTRODUCTION

### Welcome

Metalform Tow and Farm takes this opportunity to welcome you as the new owner of a *Tow and Mow*. We want you to get the best results from your new topper and this user manual will help you achieve this objective.

The safe operation and maintenance of your *Tow and Mow* is very important to prevent personal injury, damage to the machine, other property and the environment. We suggest you read and fully understand its coverage and your responsibilities of ownership prior to operating the machine or carrying out maintenance.

Best wishes and kind regards,

#### **New Zealand**

Metalform Tow and Farm  
74 Miller Street  
Dannevirke, 4930  
New Zealand  
Phone: +64 6 374 7043  
Email: [sales@towandfarm.co.nz](mailto:sales@towandfarm.co.nz)  
Web: [www.towandfarm.co.nz](http://www.towandfarm.co.nz)

#### **Australia**

Tow and Farm  
105-117 Boundary Road  
Laverton North, VIC 3026  
Australia  
Phone: 1300 630 279  
Email: [sales@towandfarm.com.au](mailto:sales@towandfarm.com.au)  
Web: [www.towandfarm.com.au](http://www.towandfarm.com.au)

#### **UK / Europe**

Tow and Farm  
Wood End  
Prospect Road  
New Farm Road Industrial Estate  
Alresford  
Hampshire, SO24 9QF  
England  
Phone: +44 1962 600 030  
Email: [sales@towandfarm.co.uk](mailto:sales@towandfarm.co.uk)  
Web: [www.towandfarm.co.uk](http://www.towandfarm.co.uk)

#### **USA / Canada**

Tow and Farm, Inc.  
105 Kendall Park Lane S,  
Atlanta GA 30336  
USA  
Phone: 877 778 7181  
Email: [sales@towandfarm.com](mailto:sales@towandfarm.com)  
Web: [www.towandfarm.com](http://www.towandfarm.com)

## INTRODUCTION

### Notes about Safety

Your safety and the safety of others are very important. Using this machine safely is an important responsibility.

To help you make informed decisions about safety, we have provided operating procedures and other information in this manual. This information alerts you to potential dangers and hazards that could injure yourself or others.

You will find safety information in the following forms;

- **Safety Labels** – displayed on the machine.
- **Safety Messages** – preceded by a safety alert symbol  and one of these three signal words; DANGER, WARNING and CAUTION.
- **Safety Headings** – such as *IMPORTANT SAFETY INFORMATION*
- **Instructions** – how to use the machine correctly and safely.

This book is filled with safety information – please read it carefully!



### **WARNING!**

Do not start, operate or service machine until you have read and understand the Owners Guide and User Manual.

Failure to do so could result in serious injury.

## CONTENTS

<b>SAFETY</b> .....	6
<b>WARRANTY</b> .....	7
<b>FEATURES &amp; CONTROLS</b> .....	8
Location of Features and Controls .....	8
Machine Height Adjustment .....	9
Storage .....	9
<b>OPERATION</b> .....	10
Safe Operation Precautions .....	10
Before Operation .....	10
Using the Tow and Mow .....	11
Hints for Operation .....	11
Troubleshooting .....	12
<b>SERVICING</b> .....	13
The Importance of Maintenance .....	13
Maintenance Safety .....	13
Maintenance Schedule .....	14
Air Filter .....	14
Engine Oil .....	14
Tyre Pressure .....	14
Lubrication .....	15
Blade Sharpening .....	15
Blade Replacement .....	15
<b>CONSUMER INFORMATION</b> .....	16
Technical Information .....	16
Serial Number Location .....	16
Spare Parts List .....	17
Spare Parts Exploded View .....	18
Consumer Help and Information .....	19















## SAFETY



Read and understand this owner's manual before operating this machine. Failure to do so could result in personal injury or equipment damage.

Know and understand the operation of all the controls. Never permit anyone to operate the machine without proper instructions.

### WARNING!

-  NEVER allow any person to ride on the Tow and Mow.
-  NEVER use on slopes with an incline greater than 9° (1:5 gradient).
-  ENSURE you read and understand the owner's manual for the tow vehicle before operation.
-  KEEP children and pets away from area of operation.
-  ENSURE the tow hitch is in good repair and fit for towing. Ensure the tow ball on the tow vehicle is the correct size for the Tow and Mow.
-  Never allow any person to stand close to the machine when it is operating.
-  Where possible avoid operating in areas with rocks and loose debris as these can be flung out at speed and may also jam the cutting spindle.
-  Eye protection and ear protection must be worn at all times.
-  Always keep top of machine clean from any grass. If grass deposits on the machine while operating, switch engines off, let stand for 30 minutes and clear.
-  Do not place hands or feet or any foreign object or body part under the Tow and Mow.
-  Never allow a person under the age of 18 years to operate the Tow and Mow.
-  Never use the Tow and Mow under the influence of alcohol or drugs.
-  Do not overfill the engines with fuel.
-  Do not spill fuel during re-filling. If spillage occurs, clean thoroughly and let stand for 30 minutes before attempting to start the engines.

## WARRANTY

We warrant the Tow and Mow against defects in materials and workmanship. The term of this warranty is one year from date of purchase.

This is a parts only warranty. You are responsible for disassembling the defective part and reassembling the new part. We shall not be responsible or liable for the cost of field labour or other charges incurred by you in removing and/or reassembling any part.

This warranty is void in circumstances where: (a) The Tow and Mow has been misused, abused, neglected or damaged; (b) The Tow and Mow has been improperly assembled, repaired, serviced or maintained; (c) The Tow and Mow has been modified; (d) The Tow and Mow has been connected to other equipment with which it is not compatible; or (e) The Tow and Mow has been used for purposes other than for which it was designed.

To make a warranty claim, contact us at the address below. Describe the problem to us. We will tell you what to do next.

If we need to inspect, test or repair the part that is the subject of your claim, it is your responsibility to ship the part to us at your cost. If we accept your warranty claim, we shall either repair or replace the defective part in our discretion. We shall then ship the part back to you at our cost.

If the Tow and Mow is off-warranty or otherwise not subject to a valid warranty claim, we will repair or replace the Tow and Mow, or part thereof, at your cost

Our sole responsibility is to repair or replace a part that is subject to a valid warranty claim. Under no circumstance will we be liable for direct, indirect, incidental, special or consequential costs or damages to the maximum extent permitted by law. The foregoing disclaimer extends to damages for personal injury, damages to other equipment, other property damage, whether suffered by you or by a third party.

We accept no liability resulting from your failure to heed the assembly, use, maintenance and safety instructions in our Owner's Guide & User Manual.

This is an express warranty. We disclaim any other express or implied warranties, including warranties of merchant-ability or fitness for purpose, to the maximum extent permitted by law.

Some jurisdictions do not allow limitations or disclaimers of implied or statutory warranties. Some jurisdictions do not allow disclaimers or exclusions of consequential or incidental damages. Therefore, the above disclaimers, limitations and exclusions may not apply in all jurisdictions in which we sell the Tow and Mow.

This warranty gives you specific legal rights. You may have other rights or remedies pursuant to the laws in your territory. Nothing in this limited warranty should be construed as limiting or restricting any other statutory right or remedy that is available to you, except for such limitations or restrictions herein as may be allowed by the law of the territory.

## FEATURES & CONTROLS

### Location of Features and Controls

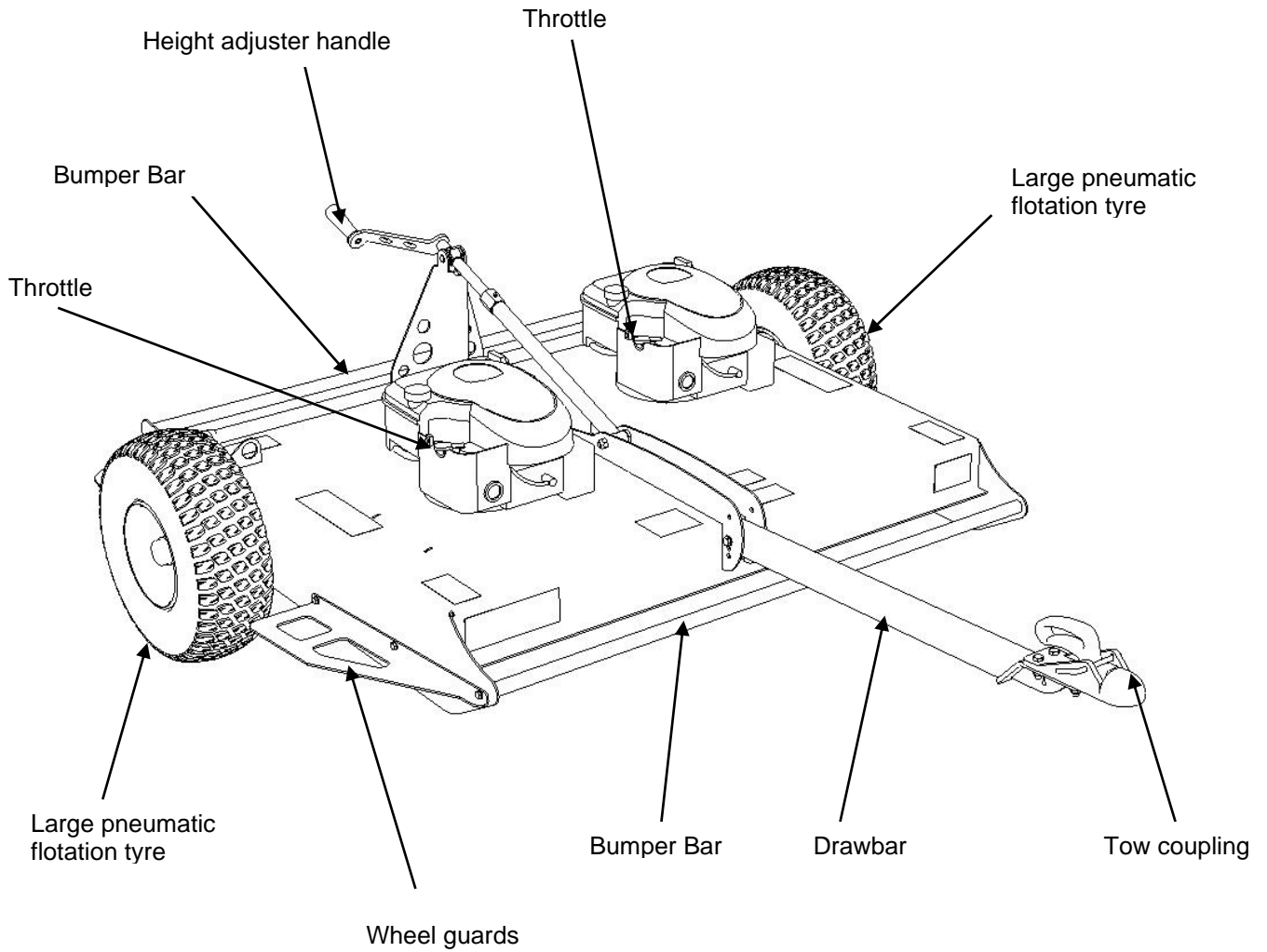



## FEATURES & CONTROLS

### Machine Height Adjustment

Height adjustment should only be done once the machine has been attached to the tow vehicle. This is because tow hitches vary in height.

- To **raise** the machine height, stand at the back of the Tow and Mow, and wind the height adjuster handle (1) in a clockwise direction. This will lift the body up.

- To **lower** the machine working height, wind the adjuster handle (1) in an anti-clockwise direction. This will lower the body down.

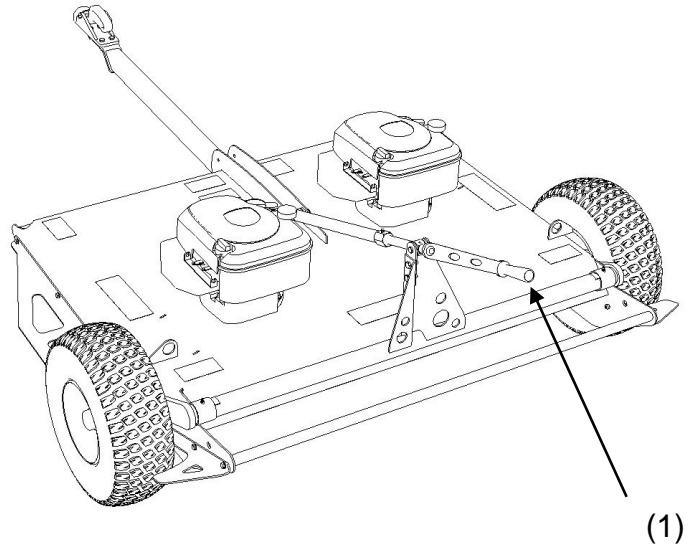

### Storage

**Ensure you store the Tow and Mow level.**

This may require a stand/block of some sort to rest the draw bar on during storage. If stored un-evenly, oil and fuel can flood the engine making it hard to start.

**X**

Incorrect Storage

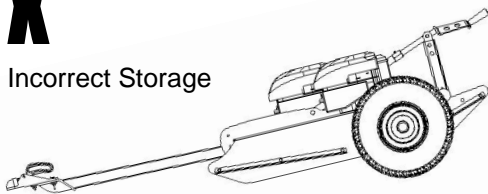

**✓**

Correct Storage

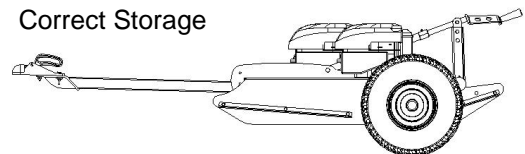

## OPERATION

### Safe Operation Precautions

Before operating machine for the first time, please review the important SAFETY information on page 5.

Before operating machine, read and understand the owners manual and safety precautions of the tow vehicle.

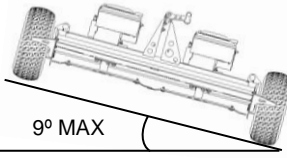
 <b>DANGER!</b>	
<p>DO NOT use on slopes with an incline greater than 9° (1:5 gradient)</p> <p>Exceeding this slope angle will cause the Tow and Mow and the tow vehicle to be unbalanced and may tip over causing death or serious injury.</p>	 <p>9° MAX</p>

### Before Operation

- Ensure the tow bar height is correctly set so that the body of the Tow and Mow sits level to the ground (or slightly higher at the FRONT). Different tow vehicles have different tow ball heights, so it's important to set the Tow and Mow to the correct height.
- Check that tyre pressure is in the range 15 – 20 psi (103 – 138 kPa). Check the condition of the tyres, look for signs of wear, cuts and impact damage. Ensure that the tyre pressure is the same in each wheel.  
**DO NOT** over inflate tyres: If the pressure is too high the Tow and Mow will bounce on rough terrain.
- Check there are no obstructions around the spindle shaft; i.e. string, wire or rags as this could create heat and destroy seals and any moving parts and put undue pressure on the engines. Ensure the blades swing freely and the spindle turns freely.
- Check that the cutting edge of the each blade is sharp and remove to sharpen if required.  
**Note:** The blade angle should be 28 degrees. (see page 17)
- Check the operation of throttle lever control.
- Check the engine oil and fuel level.

## OPERATION

### Using the Tow and Mow

The Tow and Mow has been designed to top your pastures as cost effectively as possible.

**NOTE:** Ensure you read and understand the Engine Owner's Manual prior to starting engine.

1. Hitch the Tow and Mow onto your ATV, 4-wheeler or any other similar stable vehicle.
2. Raise the Tow and Mow height to the highest possible limit.
3. Start the engine  
**(Do not attempt to start the motors without the Tow and Mow being connected to the towing vehicle.)**
  - a. Move the throttle lever from the Idle/Stop position to the Choke/Start position.
  - b. Pull the start cord using a firm consistent pull until engine fires.
  - d. Once engine has started, return the throttle lever to the idle position and let the engine warm up for 2-3 minutes before using.
  - e. Repeat steps a. – d. for other engine.
  - f. **NOTE:** After warm up, the throttle must be placed **at full revs** for operation.
4. Set the height of the Tow and Mow - dependent on intended grass length and current ground conditions.
5. Drive around the paddock/field focusing on the areas requiring topping.  
**NOTE:** Should the motor(s) stall while cutting, move the Tow and Mow onto shorter grass prior to restarting motors, as described from Step 3.
6. Turn off the engine when topping is complete and prior to travel back to storage area.

**NOTE:** Do not attempt re-fuelling of engines while they are hot. Let engines stand for at least 30 minutes before re-fuelling.

See [www.towandfarm.com](http://www.towandfarm.com) for videos and more information.

### Hints for Operation

**NOTE:** Recommended tow vehicle capacity is 300cc or higher. Minimum is 250cc.

- Finding the perfect settings for your Tow and Mow largely depends on the current conditions of your pasture. So if you don't get it right the first time, don't be concerned.
- Topping speed is dependant on grass length.  
Approximately 5km/hr (fast walking pace) for general topping.  
Speed can be increased up to 12 km/hr if grass/pasture is shorter.

## OPERATION

### Troubleshooting

#### **My Tow and Mow does not start easy!**

- Ensure you store the Tow and Mow level. This may require a stand/block of some sort to rest the draw bar on during storage.

#### **My Tow and Mow is not cutting correctly!**

- Check condition of blades on both spindles. Blades should be parallel to spindle plate.

#### **My Tow and Mow engine/engines keeps stalling!**

- The motor is working harder than designed to. Reduce towing speed OR raise cutting height.
- Ensure machine is set level or slightly higher at front (no more than 10mm); otherwise blades on front spindle will scalp the ground.
- 

#### **The engine keeps returning to an idle during operation!**

- Check locking tab on throttle base plate and adjust if required.

#### **What petrol should I be using?**

- In most circumstances, 91 octane fuel is suitable. Refer to Engine User Manual for more information to ensure you don't make warranty void.

#### **What oil should I be using?**

- In most circumstances, SAE 30 oil is suitable. Refer to Engine User Manual for more information to ensure you don't make warranty void.

## SERVICING

### The Importance of Maintenance

Good maintenance is essential for safe, economical and trouble-free operation.

To help you properly care for your Tow and Mow, the following pages include a maintenance schedule, routine inspection procedures, and simple maintenance procedures using basic hand tools. Other service tasks that are more difficult, or that require specific tools, should be carried out by a qualified service technician or qualified mechanic.

The maintenance schedule applies to normal operating conditions.

### Maintenance Safety

 **WARNING!**

Always follow procedures and precautions in the owner's manual.

- Read the instructions before you begin and make sure you have the tools and the skills required.
- To reduce possibility of fire or explosion, be careful when working around gasoline. Use only a non-flammable solvent, NOT gasoline, to clean parts. Keep cigarettes, sparks and flames away from all fuel-related parts.

To ensure the best quality and reliability, use only new genuine Tow and Farm parts or their equivalent for repair and replacement.

## SERVICING

### Maintenance Schedule

Item	Each Use	Every month or 10 hrs	Every 3 months or 25 hrs	Every 6 months or 50 hrs	Every 12 months or 100 hrs	Refer to Page
<i>Check Air Filter*</i>	√					16
<i>Check Engine Oil*</i>		√				16
<i>Check Tyre Pressure</i>			√			16
<i>Lubrication</i>			√			17
<i>Blade Sharpening</i>			√			17
<i>Blade Replacement</i>				√		17

Perform at every indicated month or operating hour interval, whichever comes first.

**\*NOTE:** See Engine User Manual for detailed information about servicing and maintaining the engine.

### Air Filter

**NOTE:** Read the Engine User Manual for details on how to check and clean the air filter element.

 **WARNING!**

A poorly maintained air cleaner increases risk of fire caused by engine backfire.

Ensure air cleaner is correctly maintained and kept clean

### Engine Oil

Read the Engine User Manual for details on how to check and replace engine oil.

### Tyre Pressure

Check that tyre pressure is in the range 15 – 20 psi (103 – 138 kPa). The factory setting is 20 psi (138 kPa). Check the condition of the tyres, look for signs of wear, cuts and impact damage. Ensure that the tyre pressure is the same in each wheel.

**DO NOT** over inflate tyres; If the pressure is too high the Tow and Mow will bounce on rough terrain, however if the pressure is too low, as the catcher fills the extra weight will compress the tyres and lower the effective brush height.

## SERVICING

### Lubrication

#### Grease Nipples

There are 4 grease nipples on the Tow and Mow Twin:

- 2 that are located on the height adjuster assembly
- 2 that are located on the torque tube which the axle arms are welded to.

See drawing on right for exact location.

Ensure they are lubricated (with Multi-Purpose grease or similar) each interval as per *Maintenance Schedule* to provide smooth operation and eliminate unnecessary wear on the height adjuster and torque tube assembly.

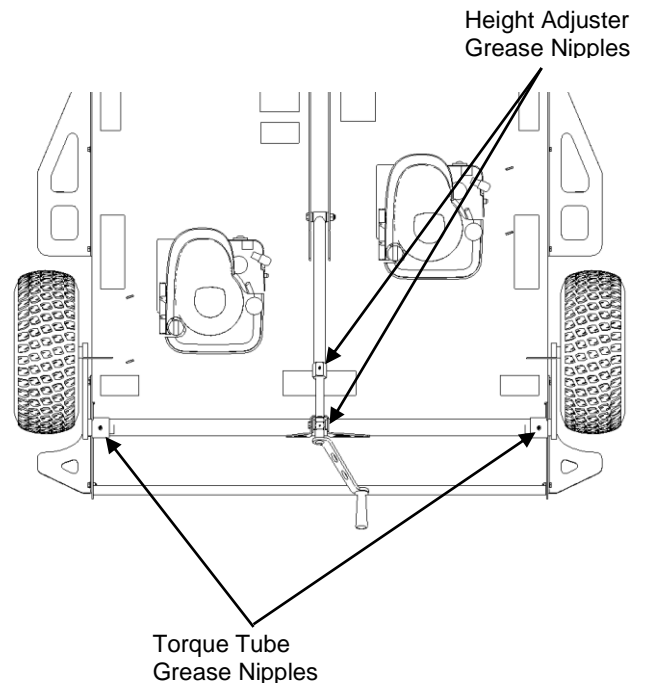

### Blade Sharpening

It is very important the blades are sharp and balanced.

When grinding the blades do not remove too much metal from one side of the blade.

The sharpened angle should be 28 degrees. When sharpening the cutting edge ensure you grind parallel with the length of the blade.

An unbalanced blade will cause excessive vibrations, very rapid wear and cause the Tow and Mow to fail.

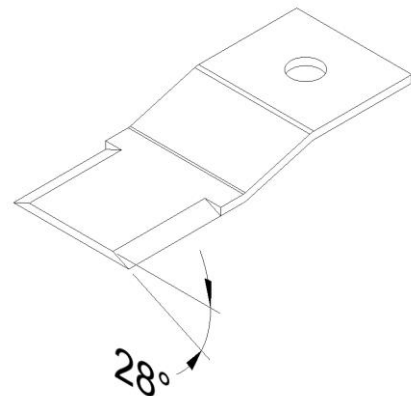

### Blade Replacement

To replace the blades, you will need to safely access the underneath of the Tow and Mow.

- Loosen the nut using a 14mm Ring Spanner. (The bolt is unable to spin)
- Remove bolt, washer and nut.
- Replace blade (use approved Tow and Farm part only)
- Insert Bolt, Flail Blade, Wavy Washer and Nut as shown on right.
- Tighten Nut to 33 Nm.

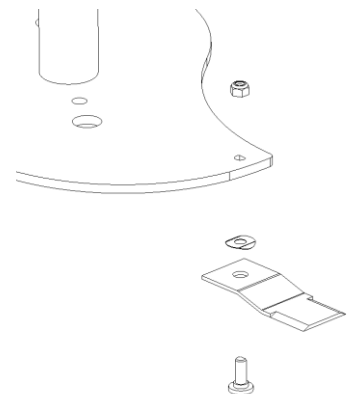

**Note:** All blades should be replaced at the same time. See page 19 for part number and description.

## CONSUMER INFORMATION

### Technical Information

Make	Tow and Mow Twin			
	1000		1270	
Model				
Cut Width	1000 mm	40"	1270 mm	50"
Overall Width	1470 mm	58"	1760 mm	70"
Height	550 mm	22"	550 mm	22"
Length - excluding tow bar - including tow bar	1200 mm 2050 mm	47" 81"	1300 mm 2350 mm	51" 93"
Weight - nett - gross	135 kg 165 kg	300 lbs 365 lbs	145 kg 175 kg	320 lbs 385 lbs
Cutting Height Adjustment	40mm - 200mm	1.5" – 7.5"	40mm - 200mm	1.5" – 7.5"
Tow Hitch Options	1 7/8" OR 50mm Tow Coupling OR 23mm Ø thru hole			
Manufactured By	Metalform (Dannevirke) Ltd			

### Serial Number Location

You will find the serial number etched onto an aluminium tag which has been applied to the Front RH side (when standing at the front) of the Tow and Mow, by the manufacturer. (See fig 7)

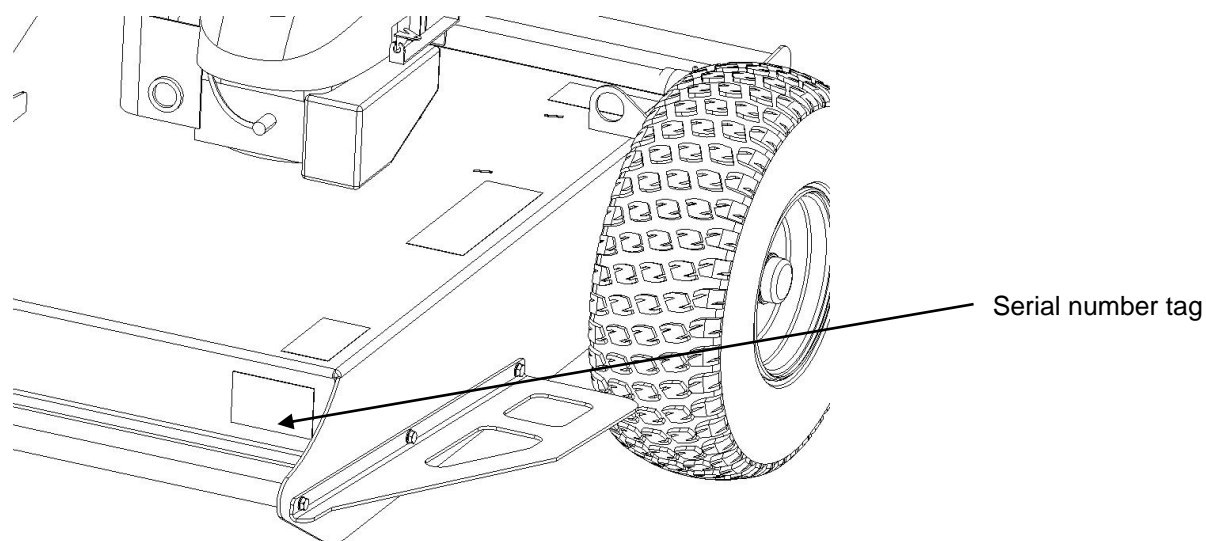

Fig 7







## CONSUMER INFORMATION

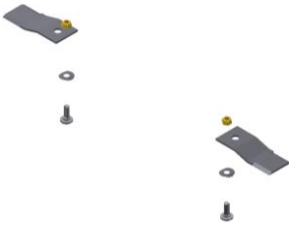

### Spare Parts List

**NOTE:** For reference purposes only. Part descriptions and/or part numbers are subject to change without notice

- For more information about each spare part pack, see [www.towandfarm.com](http://www.towandfarm.com).
- During any correspondence with Tow and Farm, ensure you have the following information handy:
  - Model and serial number
  - Date of purchase
  - Your name and address
  - Detailed description of the problem

<b>Description</b>	<b>Part Number</b>	<b>Image</b>	<b>Ref (pg)</b>
<b>Anti Scalp Disc (optional for 1270 only)</b>  1 x Disc 6 x Bolts 6 x Nuts	TT_200_A219		location on machine page 20 item 1
<b>Flail Blade Kit</b>  2 x Blade 2 x Flail Bolt 2 x Wavy Washer 2 x Nut	TMG_A01_022		fitting instr. page 17  location on machine page 20 item 2
<b>Height Adjust Handle Kit</b>  Complete Assembly	CP_002_008		location on machine page 20 item 3
<b>Spindle Bearing</b>  1 x Bearing 2 x Grub Screws	YAR208-2F		location on machine page 20 item 4
<b>Tow Coupling 1 7/8"</b>  1 x Tow Coupling 1 7/8"	99590		location on machine page 20 item 5

## Spare Parts List (continued)

<b>Description</b>	<b>Part Number</b>	<b>Image</b>	<b>Ref (pg)</b>
<b>Tow Coupling 50mm</b> 1 x Tow Coupling 50mm	R93963		location on machine page 20 item 6
<b>Tyre and Wheel Kit</b> 1 x Tyre 1 x Wheel (fitted)	TOCO-A01-007		location on machine page 20 item 7

## Spare Parts Exploded View

Refer to Spare parts Lists on pages 19-20 for Part Numbers and Descriptions

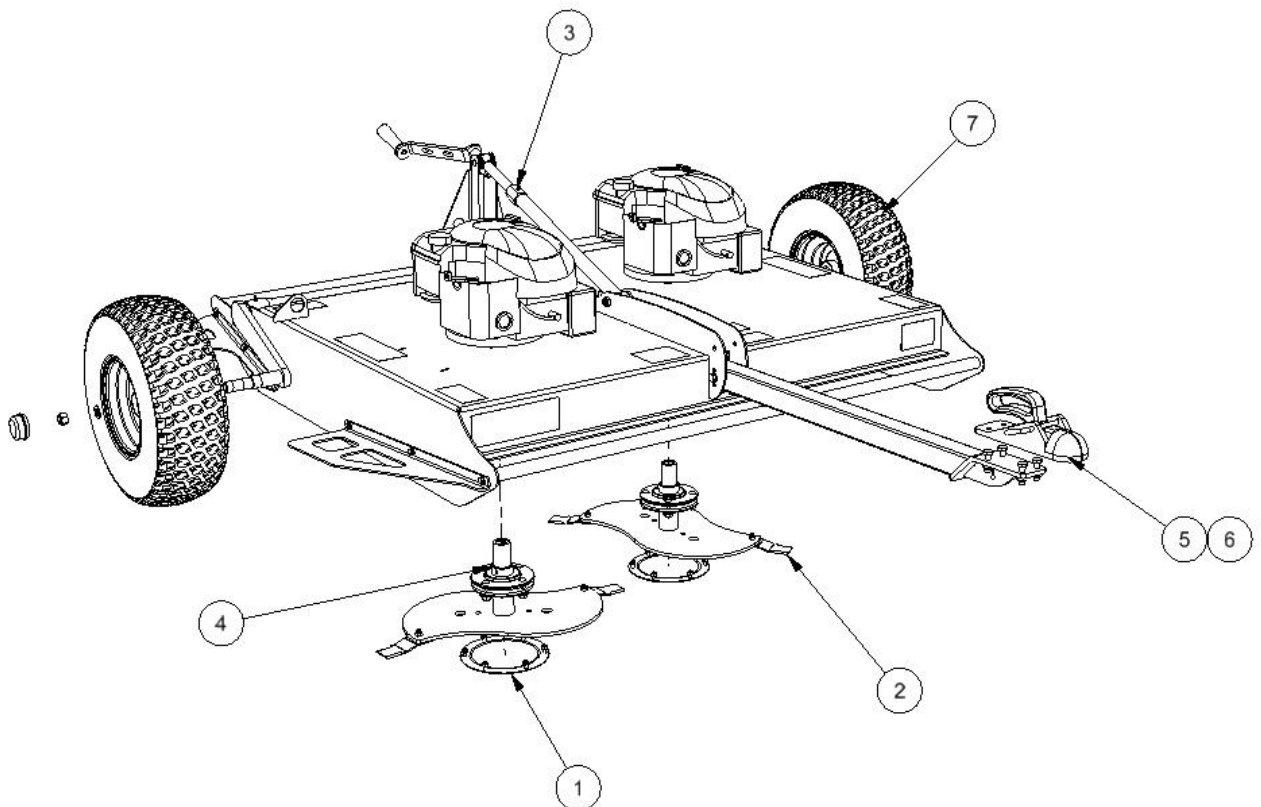

## CONSUMER INFORMATION

### Consumer Help and Information

For more help on your Tow and Mow product, please contact your local distributor.  
Contact details are found at [www.towandfarm.com](http://www.towandfarm.com)

If you are dissatisfied with any part of the Tow and Mow product or service, we welcome your comments and feedback.

You can write to Head Office: Metalform - Tow and Farm  
Easton Street  
Dannevirke, 4930  
New Zealand

Email: [support@towandfarm.co.nz](mailto:support@towandfarm.co.nz)

Or Phone: +64 6 374 7043

When you write or call, please give us the following information:

- Model and serial number
- Date of purchase
- Your name and address
- Detailed description of the problem

**New Zealand**

Metalform Tow and Farm  
74 Miller Street  
Dannevirke, 4930  
New Zealand  
Phone: +64 6 374 7043  
Email: [sales@towandfarm.co.nz](mailto:sales@towandfarm.co.nz)  
Web: [www.towandfarm.co.nz](http://www.towandfarm.co.nz)

**Australia**

Tow and Farm  
105-117 Boundary Road  
Laverton North, VIC 3026  
Australia  
Phone: 1300 630 279  
Email: [sales@towandfarm.com.au](mailto:sales@towandfarm.com.au)  
Web: [www.towandfarm.com.au](http://www.towandfarm.com.au)

**UK / Europe**

Tow and Farm  
Wood End  
Prospect Road  
New Farm Road Industrial Estate  
Alresford  
Hampshire, SO24 9QF  
England  
Phone: +44 1962 600 030  
Email: [sales@towandfarm.co.uk](mailto:sales@towandfarm.co.uk)  
Web: [www.towandfarm.co.uk](http://www.towandfarm.co.uk)

**USA / Canada**

Tow and Farm, Inc.  
105 Kendall Park Lane S,  
Atlanta GA 30336  
USA  
Phone: 877 778 7181  
Email: [sales@towandfarm.com](mailto:sales@towandfarm.com)  
Web: [www.towandfarm.com](http://www.towandfarm.com)